



ONE MONROE



CASTER-PRO[®]
CASTERS BY ONEMONROE

www.onemonroe.com | heretohelp@askmonroe.com • 1-800-858-7801



INSTITUTIONAL 03/04 SERIES

The Institutional Series is a competitive, core lineup of 1-1/4" wide casters designed and mass-produced for a wide range of applications. ANSI-ICWM:2018 tested to provide working load capacities up to 350 lbs. per caster, Institutional Series is an economical and in-stock 1-1/4" wide offering you can depend on. Institutional Series is available in a variety of size, wheel, fastening, and brake options and features our one-year standard warranty.

FEATURES

- The industry's most popular 1-1/4" wide caster sizes, wheels, fastenings, brakes, and accessories
- Thick, high-strength steel construction
- Dual ball bearing raceway design
- Raceway dust cap standard on all swivel models for increased caster life and performance
- Dynamic load capacities up to 350 lbs. per caster
- Durable RoHS compliant zinc finish
- 3/8" diameter nut and bolt axle
- Full thread guards and precision ball bearings on SPB and PPB wheels provide smooth and quiet performance and help prevent debris from entangling wheel



APPLICATIONS

- Carts
- Material Handling Equipment
- Storage Equipment/Cabinets
- Institutional Equipment
- Store Fixtures
- Office Equipment
- Food Service
- Hospitality Carts

BRAKE OPTIONS



Wheel Brake

Utilizes a lower sitting brake lever (on/off) that engages and disengages a brake arm that securely locks on the face of the wheel when engaged. See below total lock to also lock the swivel section of the caster.



Total Lock

Integrated brake pedal simultaneously locks both wheel and swivel section of caster when engaged. Simply push the "OFF" portion of the brake pedal to resume full mobility of wheel and swivel.

WHEEL & BEARING OPTIONS

SPB



Thermo-Rubber (SPB) wheels provide excellent floor protection, are resistant to most chemical/oils, and help reduce vibration by absorbing shock. Standard precision ball bearings provide easy and quiet rolling. Full thread guards prevent debris from entangling the axles.

Durometer: 75A (±5)
Temp Range: -40°F to +180°F

PPB



Thermo-Urethane (PPB) wheels are the most ergonomic and easiest to roll, provide excellent floor protection, and are highly resistant to chemicals/oils. Standard precision ball bearings provide easy and quiet rolling. Full thread guards prevent debris from entangling the axles.

Durometer: 90A (±5)
Temp Range: -40°F to +180°F

PBD



Polyolefin (PBD) wheels are the most economical wheel. Wheels come with DuPont engineered Delrin bearings which are extremely durable under a wide range of temperature and humidity conditions. They are also corrosion resistant and lightweight.

Durometer: 70D (±5)
Temp Range: -40°F to +180°F



Precision Ball

Centered Precision Ball Bearing standard on Thermo-Rubber (SPB) and Thermo-Urethane (PPB) wheels



Delrin®

Comes standard on Polyolefin (PBD) wheels



CASTER MODELS AND SPECIFICATIONS

Wheel Diameter	Thread Width	Wheel Material	Load Capacity (lbs)	Mounting Height	Swivel Radius	Standard Bearing	Thread Guard Type	Swivel	Rigid	Wheel Brake (-WB)	Total Lock Brake (-TTL)
3"	1 1/4"	Thermo-Rubber (SPB)	210	Plate: 4 1/4" Stem: 4 1/8"	2 15/16" See below for brake models	Precision Ball	Full	03-SPB-3	04-SPB-3	03-SPB-3-WB	03-SPB-3-TTL
		Thermo-Urethane (PPB)	250			Precision Ball	Full	03-PPB-3	04-PPB-3	03-PPB-3-WB	03-PPB-3-TTL
		Polyolefin (PBD)	270			Delrin	None	03-PBD-3	04-PBD-3	03-PBD-3-WB	03-PBD-3-TTL
3 1/2"	1 1/4"	Thermo-Rubber (SPB)	250	Plate: 4 3/4" Stem: 4 5/8"	3 1/8" See below for brake models	Precision Ball	Full	03-SPB-35	04-SPB-35	03-SPB-35-WB	03-SPB-35-TTL
		Thermo-Urethane (PPB)	275			Precision Ball	Full	03-PPB-35	04-PPB-35	03-PPB-35-WB	03-PPB-35-TTL
4"	1 1/4"	Thermo-Rubber (SPB)	275	Plate: 5 1/4" Stem: 5 1/8"	3 3/8" See below for brake models	Precision Ball	Full	03-SPB-4	04-SPB-4	03-SPB-4-WB	03-SPB-4-TTL
		Thermo-Urethane (PPB)	300			Precision Ball	Full	03-PPB-4	04-PPB-4	03-PPB-4-WB	03-PPB-4-TTL
		Polyolefin (PBD)	275			Delrin	None	03-PBD-4	04-PBD-4	03-PBD-4-WB	03-PBD-4-TTL
5"	1 1/4"	Thermo-Rubber (SPB)	325	Plate: 6 1/4" Stem: 6 1/8"	3 7/8" See below for brake models	Precision Ball	Full	03-SPB-5	04-SPB-5	03-SPB-5-WB	03-SPB-5-TTL
		Thermo-Urethane (PPB)	350			Precision Ball	Full	03-PPB-5	04-PPB-5	03-PPB-5-WB	03-PPB-5-TTL
		Polyolefin (PBD)	325			Delrin	None	03-PBD-5	04-PBD-5	03-PBD-5-WB	03-PBD-5-TTL

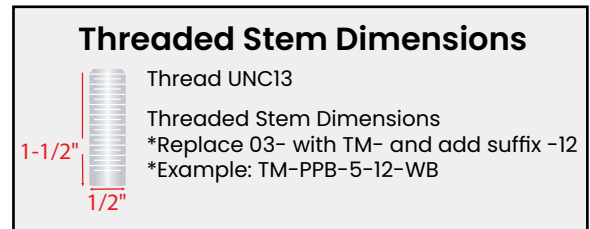
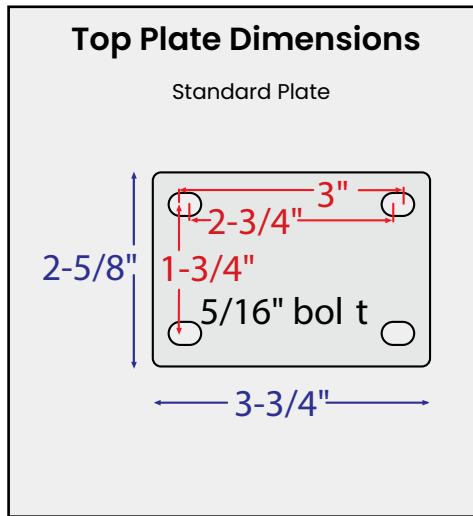

WHEEL GUIDE



Thermo-Rubber (SPB)

Thermo-Rubber (SPB) wheels provide excellent floor protection, are resistant to most chemical/oils, and help reduce vibration by absorbing shock. Standard precision ball bearings provide easy and quiet rolling. Full thread guards prevent debris from entangling the axles.

Durometer: 75A (±5) Temp Range: -40°F to +180°F



Thermo-Urethane (PPB)

Thermo-Urethane (PPB) wheels are the most ergonomic and easiest to roll, provide excellent floor protection, and are highly resistant to chemicals/oils. Standard precision ball bearings provide easy and quiet rolling. Full thread guards prevent debris from entangling the axles.

Durometer: 90A (±5) Temp Range: -40°F to +180°F



Polyolefin (PBD)

Polyolefin (PBD) wheels are the most economical wheel. Wheels come with DuPont engineered Delrin bearings which are extremely durable under a wide range of temperature and humidity conditions. They are also corrosion resistant and lightweight.

Durometer: 70D (±5) Temp Range: -40°F to +180°F

BRAKE SWIVEL RADIUS

Wheel Diameter	Brake Type	Swivel Radius
3"	Wheel Brake	3 3/4"
	Total Lock Brake	4 3/8"
3 1/2"	Wheel Brake	3 3/4"
	Total Lock Brake	4 7/16"
4"	Wheel Brake	3 3/4"
	Total Lock Brake	4 7/16"
5"	Wheel Brake	3 7/8"
	Total Lock Brake	4 7/16"

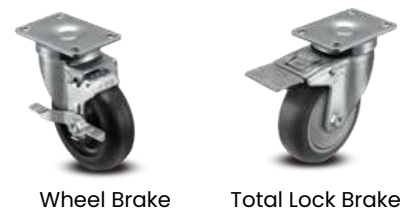



MEDIUM-HEAVY DUTY S1/R1 SERIES

The S1/R1 Series is an economical lineup of casters and wheels designed and mass-produced for a range of medium-duty applications with load requirements ranging from 300 to 1,250 lbs. per caster. From shop carts and containers, to platform and lumber carts, the S1/R1 Series is your most competitive and in-stock 2" wide solution.

FEATURES

- The industry's most popular 2" wide caster sizes, wheel options, brake configurations, and accessories.
- Capacities up to 1,250 lbs. per caster.
- Double ball raceways for smooth swiveling action.
- 1/4" thick steel leg construction on swivel and rigid casters; 3/16" construction on total lock casters.
- 5/8" diameter permanent rivet kingpin.
- RoHS compliant industrial zinc finish for corrosion resistance.
- 1/2" hollow axle with grease zerk and lock nut.
- Total lock permanently integrated into swivel fork on total lock models.

Top Plate Dimensions

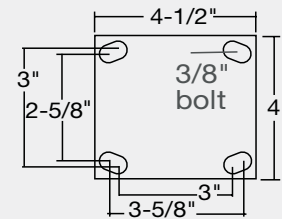

WHEEL OPTIONS

POLYURETHANE TREAD WHEELS



Thermo-Urethane (Maroon/Grey)

- Polyurethane tread mechanically locked to polypropylene core.
 - Attractive, all-purpose wheel.
 - Good in wet applications, resistant to most chemicals.
- Durometer: 95 Shore A (±5)**



Example of Thermo-Urethane in a caster



Mold-on Poly

- Polyurethane bonded to cast iron core.
 - High load capacity.
 - Good roll-ability and floor protection.
- Durometer: 95 Shore A (±5)**

THERMO-RUBBER CUSHION WHEELS



Thermo-Rubber Donut

- Non-marking tread.
 - Good floor protection.
 - Quiet, shock-absorbing ride.
 - Good in wet environments, resistant to most chemicals.
- Durometer: 90 Shore A (±5)**



Example of Thermo-Rubber Donut in a caster

HARD TREAD WHEELS



Phenolic

- High load capacity.
 - Hard tread, rolls easily.
 - Excellent impact strength.
 - Abrasion-resistant.
- Durometer: 90 Shore D (±5)**



Example of Phenolic in a caster



Cast Iron

- Solid one-piece construction.
- High load capacity.
- Hard tread, rolls easily.
- Excellent impact strength.
- For high temperature up to 600°F – must use optional steel retainer washers (SW).

CASTER MODELS AND SPECIFICATIONS



Wheel Diameter	Tread Width	Wheel Material	Load Capacity (lbs)	Mounting Height	Swivel Radius	Swivel	Rigid	Wheel Brake (-WB)
4"	2"	Thermo-Urethane (Maroon on Gray)	500	5 5/8"	3 3/8"	S142R-PP	R142R-PP	S142R-PP-WB
		Mold-on Poly	800			S142R-PI	R142R-PI	S142R-PI-WB
		Thermo-Rubber (Donut)	300			S142R-SP-RD	R142R-SP-RD	S142R-SP-RD-WB
		Phenolic	800			S142R-PH	R142R-PH	S142R-PH-WB
		Cast Iron	800			S142R-SS	R142R-SS	S142R-SS-WB
5"	2"	Thermo-Urethane (Maroon on Gray)	600	6 1/2"	4"	S152R-PP	R152R-PP	S152R-PP-WB
		Mold-on Poly	1100			S152R-PI	R152R-PI	S152R-PI-WB
		Thermo-Rubber (Donut)	350			S152R-SP-RD	R152R-SP-RD	S152R-SP-RD-WB
		Phenolic	1000			S152R-PH	R152R-PH	S152R-PH-WB
		Cast Iron	1000			S152R-SS	R152R-SS	S152R-SS-WB
6"	2"	Thermo-Urethane (Maroon on Gray)	720	7 1/2"	4 3/4"	S162R-PP	R162R-PP	S162R-PP-WB
		Mold-on Poly	1200			S162R-PI	R162R-PI	S162R-PI-WB
		Thermo-Rubber (Donut)	500			S162R-SP-RD	R162R-SP-RD	S162R-SP-RD-WB
		Phenolic	1200			S162R-PH	R162R-PH	S162R-PH-WB
		Cast Iron	1200			S162R-SS	R162R-SS	S162R-SS-WB
8"	2"	Thermo-Urethane (Maroon on Gray)	800	9 1/2"	6 1/4"	S182R-PP	R182R-PP	S182R-PP-WB
		Mold-on Poly	1250			S182R-PI	R182R-PI	S182R-PI-WB
		Thermo-Rubber (Donut)	600			S182R-SP-RD	R182R-SP-RD	S182R-SP-RD-WB
		Phenolic	1250			S182R-PH	R182R-PH	S182R-PH-WB
		Cast Iron	1250			S182R-SS	R182R-SS	S182R-SS-WB

BRAKE OPTIONS

SWIVEL BRAKE OPTIONS



Wheel Brake (-WB)
*Other brake options available

RIGID BRAKE OPTIONS



Wheel Brake (-WB)

BEARING OPTIONS



Roller Standard (R)
*Other bearing options available

SWIVEL RADIUS: BRAKE CASTERS



S162R-PI-WB



S162R-SS

Wheel Dia.	-WB
4"	3-5/8"
5"	4"
6"	4-3/4"
8"	6-1/4"



SL - 1

4-Position Swivel Lock
Lock and unlock swivel for easy tracking down hallways.



HEAVY DUTY KINGPINLESS SERIES SKP1/RKP1

The Heavy Duty Kingpinless Series is ideal for applications where standard kingpin casters will simply not hold up to shock or impact. These casters are perfect for power-towed applications, dough troughs, and heavy duty tooling fixtures.

FEATURES

- Capacities up to 1,250lbs
- 5/16" AISI 1045 steel top plate
- Swivel section with one row of 3/8" ball bearings mounted in a precision machined 2 3/8" diameter raceway
- 1/2" Hollow axle with grease zerk and lock nut
- Available wheel options shown on page 4
- Wheels come standard with Roller Bearings
- Other Bearing and Wheel options available



CASTER MODELS AND SPECIFICATIONS

Wheel Diameter	Tread Width	Wheel Material	Load Capacity (lbs)	Mounting Height	Swivel Radius	Swivel	Rigid
4"	2"	Thermo-Urethane (Maroon on Gray)	500	5 5/8"	3 3/16"	SKP142R-PP	RKP142R-PP
		Mold-on Poly	800			SKP142R-PI	RKP142R-PI
		Thermo-Rubber (Donut)	300			SKP142R-SP-RD	RKP142R-SP-RD
		Phenolic	800			SKP142R-PH	RKP142R-PH
		Cast Iron	800			SKP142R-SS	RKP142R-SS
5"	2"	Thermo-Urethane (Maroon on Gray)	600	6 1/2"	3 7/8"	SKP152R-PP	RKP152R-PP
		Mold-on Poly	1100			SKP152R-PI	RKP152R-PI
		Thermo-Rubber (Donut)	350			SKP152R-SP-RD	RKP152R-SP-RD
		Phenolic	1000			SKP152R-PH	RKP152R-PH
		Cast Iron	1000			SKP152R-SS	RKP152R-SS
6"	2"	Thermo-Urethane (Maroon on Gray)	720	7 1/2"	4 9/16"	SKP162R-PP	RKP162R-PP
		Mold-on Poly	1200			SKP162R-PI	RKP162R-PI
		Thermo-Rubber (Donut)	500			SKP162R-SP-RD	RKP162R-SP-RD
		Phenolic	1200			SKP162R-PH	RKP162R-PH
		Cast Iron	1200			SKP162R-SS	RKP162R-SS
8"	2"	Thermo-Urethane (Maroon on Gray)	800	9 1/2"	6 1/4"	SKP182R-PP	RKP182R-PP
		Mold-on Poly	1250			SKP182R-PI	RKP182R-PI
		Thermo-Rubber (Donut)	600			SKP182R-SP-RD	RKP182R-SP-RD
		Phenolic	1250			SKP182R-PH	RKP182R-PH
		Cast Iron	1250			SKP182R-SS	RKP182R-SS

Top Plate Dimensions

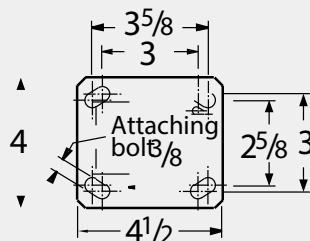

Swivel Section

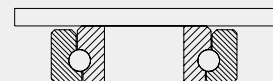



EXTRA HEAVY DUTY KINGPINLESS SERIES SKP7/RKP7

The Extra Heavy Duty Kingpinless Series is ideal for applications where greater weight capacities are required, exceeding the limit of standard 2" wide wheels. These casters are perfect for heavy duty power-towed applications, large bakery racks, and production dollies.

FEATURES

- Capacities up to 2,500lbs
- 5/16" AISI 1045 steel top plate
- 3/8" thick legs welded inside and out
- 3/4" Axle and nut
- RoHS Zinc Plating
- Available with Polyurethane on Iron or Phenolic wheels
- Wheels come standard with Roller Bearings
- Other Bearing and Wheel options available



CASTER MODELS AND SPECIFICATIONS

Wheel Diameter	Tread Width	Wheel Material	Load Capacity (lbs)	Mounting Height	Swivel Radius	Swivel	Rigid
6"	3"	Polyurethane on Iron	2000	7 1/2"	4 3/8"	SKP763R-PI	RKP763R-PI
		Phenolic	2000			SKP763R-PH	RKP763R-PH
8"	3"	Polyurethane on Iron	2500	10 1/8"	6 1/16"	SKP783R-PI	RKP783R-PI
		Phenolic	2500			SKP783R-PH	RKP783R-PH

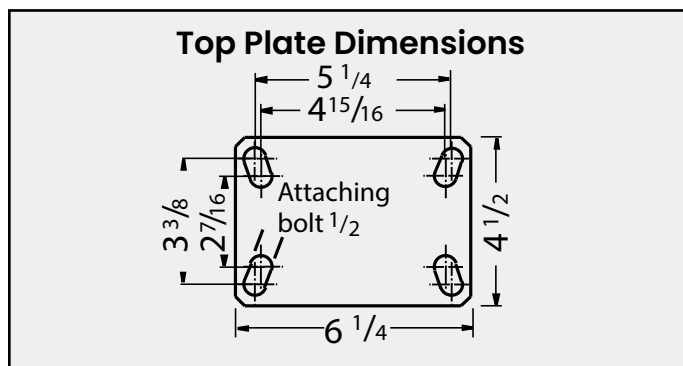

Need specification help?
Contact your Caster-Pro® expert today!
1-800-858-7801



ONEMONROE

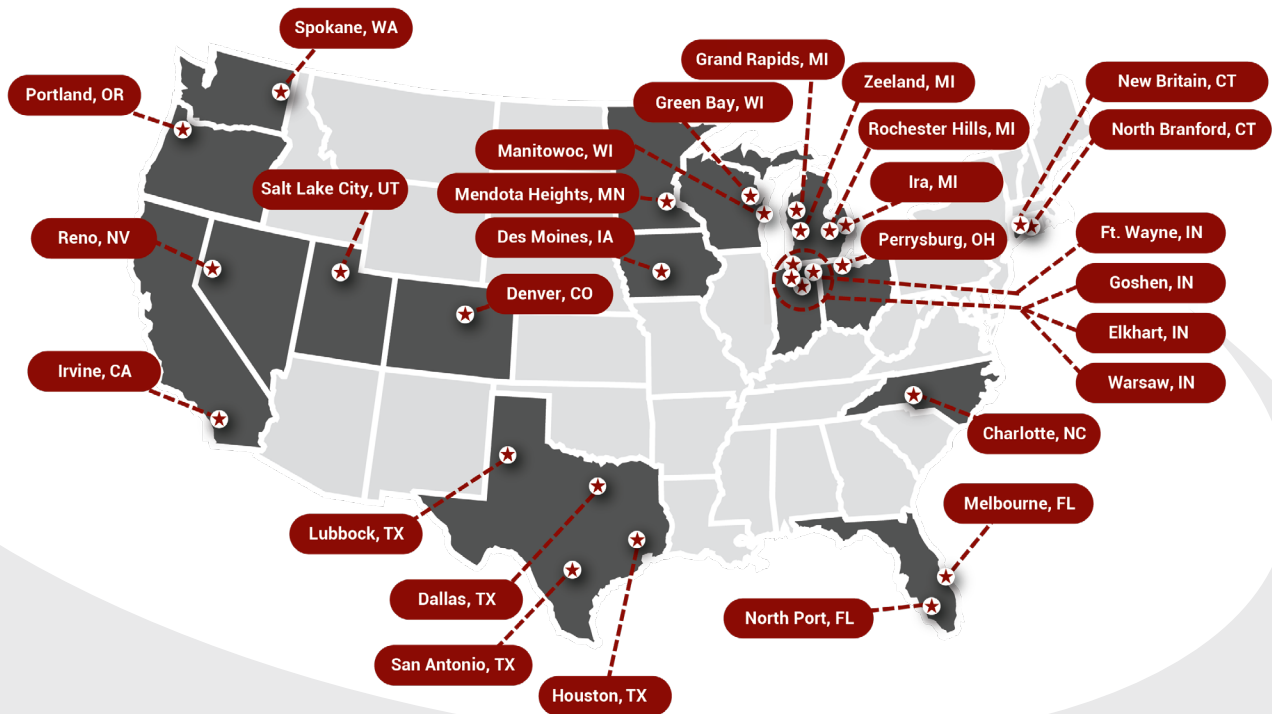

How can we help?

www.onemonroe.com | heretohelp@askmonroe.com